

Determination of trace amounts of bromide by flow injection/stopped-flow detection technique using kinetic-spectrophotometric method

K. Uraisin^a, D. Nacapricha^b, S. Lapanantnoppakhun^c, K. Grudpan^c, S. Motomizu^{a,*}

^a Department of Chemistry, Faculty of Science, Okayama University, 3-1-1 Tsushima-naka, Okayama 700-8530, Japan

^b Department of Chemistry, Faculty of Science, Mahidol University, Rama VI Road, Bangkok 10400, Thailand

^c Department of Chemistry, Faculty of Science, Chiang Mai University, Chiang Mai 50200, Thailand

Received 1 June 2005; received in revised form 19 July 2005; accepted 19 July 2005

Available online 30 August 2005

Abstract

A simple, sensitive and selective method for the determination of bromide in seawater by using a flow injection/stopped-flow detection technique was examined. The detection system was developed for a new kinetic-spectrophotometric determination of bromide in the presence of chloride matrix without any extraction and/or separation. The detection was based on the kinetic effect of bromide on the oxidation of methylene blue (MB) with hydrogen peroxide in a strongly acidic solution. Large amounts of chloride could enhance the sensitivity of the method as an activator. The decolorisation of the blue color of MB was used for the spectrophotometric determination of bromide at 746 nm. A stopped-flow approach was used to improve the sensitivity of the measurement and provide good linearity of the calibration over the range of 0–3.2 $\mu\text{g ml}^{-1}$ of bromide. The relative standard deviation was 0.74% for the determination of 2.4 $\mu\text{g ml}^{-1}$ bromide ($n = 5$). The detection limit (3σ) was 0.1 $\mu\text{g ml}^{-1}$ with a sampling frequency of 12 h^{-1} . The influence of potential interfering ions was studied. The proposed method was applied to the determination of bromide in seawater samples and provided satisfactory results.

© 2005 Elsevier B.V. All rights reserved.

Keywords: Stopped-flow injection; Kinetic spectrophotometry; Methylene blue; Bromide; Seawater

1. Introduction

Bromide ion is one of the constituents of ground water, surface water and seawater. Some oxidizing agent in such waters may oxidize bromide ion to liberating bromine. Bromide can combine with many types of organic pollutants present in waters to form toxic compounds of bromo-derivatives, which can cause serious harm to human health and environment. Moreover, bromide ion in source water for potable water is the one of precursor to the formation of bromate, which is harmful disinfection byproduct (DBP) in drinking water. Bromide concentration in water sources near the sea is entirely dependent on the amount of seawater mixing with ground and surface water. Therefore, sensi-

tive and selective methods are required for their reliable quantification.

Bromide has been determined using a wide variety of analytical techniques, such as high performance liquid chromatography [1,2], ion chromatography [3–5], gas chromatography [6] and capillary electrophoresis [7–10]. Although these methods are highly sensitive, their instruments are expensive and the determination procedure is complicated as well. Moreover, they suffer from long times due to the necessity of the sample preparation steps. Several kinds of kinetic-spectrophotometric methods based on the catalytic effect of bromide on coloration reactions with organic compounds have been reported [11–19]. In these methods, manual procedures for kinetic measurements are tedious and time-consuming, and are sometimes complicated. Such disadvantages in manual batchwise procedures can be overcome by using flow injection analysis (FIA), since FIA techniques can

* Corresponding author. Tel.: +81 86 277 5715; fax: +81 86 277 5715.
E-mail address: motomizu@cc.okayama-u.ac.jp (S. Motomizu).

strictly fix the timing of the measurement of the catalytic reaction and the mixing of the solutions of reagent and sample with rapid sample throughput [20]. Several FIA procedures have been reported for the determination of bromide utilizing the catalytic effect of bromide on the redox reaction between tetrabase and chloramines T [21] and the reaction between *m*-cresosulfonephthalein and periodate [22]. However, high concentrations of chloride in millimolar can often interfere with these catalytic reactions, which lead to the difficulty to apply such kinetic reactions to the determination of bromide in the presence of chloride matrix, as in seawater. Some FIA methods based on different principles also have been proposed for bromide determination [23–26]. One of them proposed the method for bromide determination in seawater sample by using chemiluminescence (CL) detection [26]. The procedure was based on the oxidation of bromide to bromine by chloramines T, followed by the reaction of bromine with luminol, which can result in CL emission. However, some metal ions interfere seriously, and can suppress the CL intensity.

In this work, bromide in seawater can be determined by flow injection/stopped-flow detection technique utilizing the new developed kinetic method proposed by Uraisin et al. [19]. The analytical method was based on the catalytic effect of bromide on the oxidation of methylene blue (MB) with hydrogen peroxide in strongly acidic solution. In this reaction system, high concentrations of chloride can act as an effective activator for the catalytic reaction of bromide. The application of FIA to a catalytic method results in a reproducible procedure with strict control of the timing, and thus overcome the inherent difficulties in kinetic method. A stopped-flow detection method was employed in this work in order to obtain higher sensitivity and less amounts of reagent consumption. The stopped-flow was obtained by using a semi-automated stopped flow-FI analyzer [27], which can control a pump and a switching valve for sample injection. The proposed method was successfully applied to the determination of bromide in seawater samples.

2. Experimental

2.1. Chemicals and reagents

All chemicals used were of analytical reagent grade and solutions were prepared using water purified with a Milli-Q system (Elix 3/Milli-Q Element, Nihon Millipore). A stock solution (1000 mg l^{-1}) of standard bromide was prepared by dissolving 0.1488 g of potassium bromide (crystals: Wako Pure Chemicals, Osaka) in 100.0 ml water. Working standard solutions of bromide were subsequently prepared by appropriate dilution of the stock solution with 0.011 mol l^{-1} sodium chloride.

The carrier stream of 0.011 mol l^{-1} sodium chloride was prepared by dissolving approximately 0.65 g sodium chloride (Wako Pure Chemicals) in 1000 ml of water. This solution

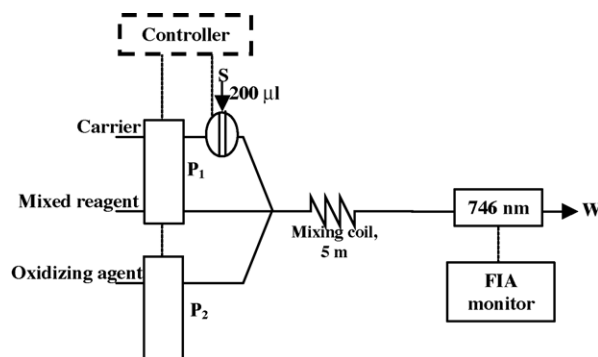

Fig. 1. Stopped-FI system for the determination of bromide. S: sample injection valve, P: double plunger pump, W: waste, carrier: 0.011 mol l^{-1} NaCl, mixed reagent: $8 \times 10^{-5} \text{ mol l}^{-1}$ methylene blue (MB), 2.5 mol l^{-1} H_2SO_4 and 0.6 mol l^{-1} NaCl, oxidizing agent: 2 mol l^{-1} H_2O_2 . The system was carried out in temperature-control room (25°C).

also can be used for the preparation of working standard solutions of bromide.

The mixed reagent stream was a solution of $8 \times 10^{-5} \text{ mol l}^{-1}$ methylene blue, 2.5 mol l^{-1} sulfuric acid and 0.6 mol l^{-1} sodium chloride. This mixture was first prepared by diluting 70 ml of 95% sulfuric acid (Wako Pure Chemicals) to 500 ml with water: this result in sulfuric acid of 2.5 mol l^{-1} . MB crystalline (Tokyo Kasei, Tokyo) of 0.013 g and sodium chloride of 17.5 g was then dissolved in this sulfuric acid solution.

The oxidizing agent of 2 mol l^{-1} hydrogen peroxide was prepared by diluting 100 ml of a commercially available solution of 30% (10 mol l^{-1}) hydrogen peroxide (Kanto Chemical Co. Inc., Tokyo) in 500 ml of water.

Seawater samples were collected at the Seaside of Okayama and Okinawa Prefecture. Filtration with a filter paper (Advantec, No. 5B) and 50-fold dilution with purified water was the only pretreatment.

2.2. Flow injection (FI) apparatus

The stopped-FI system used is schematically depicted in Fig. 1. The manifold was equipped with two double plunger pumps (PUMP 201, F.I.A Instruments, Japan), six-port injection valve (SNK, Japan), a spectrophotometer (Soma Visible Detector S-3250) equipped with a 10 mm flow-through cell and a signal recording FIA monitor/data processing apparatus (F.I.A Instruments). The manifolds were constructed from PTFE tubing with i.d. of 0.5 mm.

2.3. Operating procedures for stopped-FI method

A simple semi-automatic stopped flow-FI analyzer developed by Grudpan et al. [27] was applied to the proposed stopped-FI system in Fig. 1. By using this analyzer, the on-off of the pump and the switching of the sample injection valve can be controlled. Table 1 illustrates the operation sequence for the proposed FI system. The carrier of NaCl, the mixed

Table 1
Time and operation sequence

Step	Time (s)	Pump	Six-way valve position	Operation
T_1	100	On	Inject	Sample zone arrested inside the flow cell
T_2	120	Off	Load	Sample zone trapped in the flow cell
T_3	100	On	Load	Wash out and load a new sample

reagent of MB/H₂SO₄/NaCl solution and the oxidizing agent of H₂O₂ were propelled at 0.5 ml min⁻¹ for each channel via double plunger pumps. The aliquots of 200 μl of standard solution (0–3.2 μg ml⁻¹) or diluted (50 times) seawater samples were injected into the carrier stream. The mixed zone of the sample and reagents was arrested inside the flow cell at exactly 100 s after the sample injection (T_1 , traveling time). After that the sample zone was trapped inside the flow cell by stopping the pumping system (T_2 , stopping time), the decreasing in the absorbance of MB at 746 nm for 2 min was monitored. Then, the solution was expelled from the flow cell by turn on the pumping system (T_3 , washing time). Fig. 2 demonstrates the stopped-FI profiles obtained by using these operation sequences. The absorbance difference between the baseline and the minimum value of the hollowed at 746 nm was used for the preparation of a calibration graph.

2.4. Procedure for titration method (the validating method)

The titration was performed according to the method recommended in “Handbook of Anion Determination” [28]. A 10.0 ml of seawater was transferred into 250 ml conical flask, followed by the addition of 5 ml of 1 mol l⁻¹ KH₂PO₄, 5 ml of 2 mol l⁻¹ NaCl and 2.5 ml of 0.35 mol l⁻¹ NaOCl. Then, the mixture was heated just to boiling and then 5 ml of 50% (w/v) HCOONa was added. The solution was then cooled and diluted to approximately 100 ml with water. A

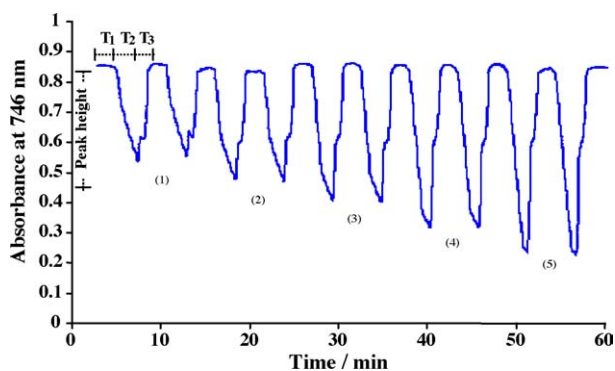

Fig. 2. Stopped-FI peaks for standard bromide solutions. (1–5) Standard bromide solutions of 0, 0.8, 1.6, 2.4 and 3.2 μg ml⁻¹, respectively. Traveling time (T_1) 100 s, stopping time (T_2) 120 s and washing time (T_3) 100 s.

15 ml of 10% (w/v) KI, 15 ml of 3 mol l⁻¹ H₂SO₄ and 1 ml of 0.1 mol l⁻¹ ammonium molybdate were added, and the mixture was titrated against a standardized Na₂S₂O₃ solution (about 2.7 × 10⁻³ mol l⁻¹), in the presence of 1% (w/v) starch as an indicator.

3. Results and discussion

In the present paper, the determination of trace amounts of bromide was based on the catalytic effect of bromide on the oxidation of MB with H₂O₂. In the presence of small quantities of bromide, MB is slightly oxidized by H₂O₂ in strongly acid solution to form an oxidized product of MB. The effect of bromide on the catalytic reaction is enhanced in the presence of large amounts of chloride [19]. This can cause a rapid color change of MB from blue to less bluish, which can be monitored spectrophotometrically at 746 nm. It was found that the rate of the decolorisation of the absorbance of MB at the beginning was very fast, and after that the rate becomes slower [19]. In order to achieve reproducible results, the mixing and measurement of kinetic-based system must be exactly timing, which can overcome using FI techniques. Moreover, the stopped-FI mode was very effective to improve the sensitivity of the kinetic-based system.

3.1. Effect of experimental variables

In order to decrease the dilution factor of sample and reagents in the flow system, all reagents, such as MB, H₂SO₄ and NaCl were mixed together. However, from our previous work [19], a large amount of chloride could act as a catalyst for the oxidation of MB with H₂O₂, without trace amounts of bromide. Therefore, H₂O₂ should be separated from the mixed reagent. The simplified stopped-FI system can be assembled as demonstrated in Fig. 1. In the previous paper [19], at higher temperature, the sensitivity was decreased. In the present study, the experimental was carried out at 25 °C.

3.1.1. Stopping-time

In this work, the optimization of stopping-time is very important from the point of view of the sensitivity of the measurement and the linearity of the calibration. Standard bromide solutions of 0–3.2 μg ml⁻¹ were injected into the FI system shown in Fig. 1. The sample zone was trapped inside the flow cell for the difference time interval after the pumping system stopped. Calibration graphs were also prepared: the linear correlation coefficient (R^2) of the calibration graphs obtain in each stopping time was also considered for selected time. As can be seen in Fig. 3, the increase in the stopping time increases gradually the sensitivity of the method. The signals obtained from all standard solutions were slightly changed, when the stopping time above 2 min, with the correlation coefficient higher than 0.99. The shortest stopping

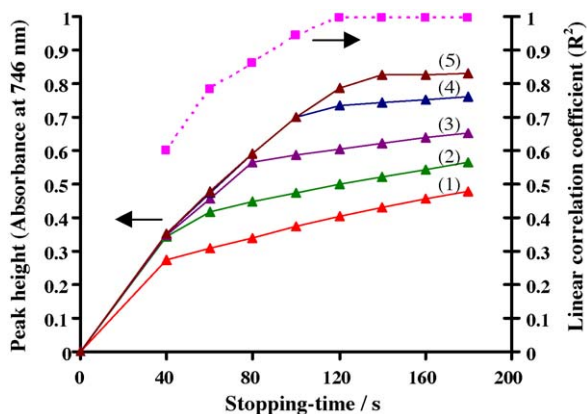

Fig. 3. Dependence of the stopping time on analytical signal of standard bromide (solid line) and linear correlation coefficient (dash line). Peak heights correspond to the absorbance differences between the baseline and the minimums of the hollows. (1–5) Standard bromide solutions of 0, 0.8, 1.6, 2.4 and $3.2 \mu\text{g ml}^{-1}$, respectively. Conditions: MB $8 \times 10^{-5} \text{ mol l}^{-1}$, H_2SO_4 2.5 mol l^{-1} , NaCl 0.6 mol l^{-1} , H_2O_2 2 mol l^{-1} , flow rate of 1.5 ml min^{-1} , mixing coil length of 5 m and injection volume of $200 \mu\text{l}$.

time, 2 min, was selected due to its high sensitivity with good linearity of the calibration.

3.1.2. Optimization of concentrations of chemicals

In strongly acidic mediums, MB gave the maximum wavelength at 746 nm, which corresponds to protonated MB. The absorbance of MB in this wavelength is strongly affected from acid concentrations. In order to achieve an applicable signal reading of baseline (0.8–0.9 a.u.), sulfuric acid concentration of 2.5 mol l^{-1} and MB concentration of $8 \times 10^{-5} \text{ mol l}^{-1}$ were selected for further studies.

A 50-fold dilution of seawater samples should be performed, prior to the determination of bromide by using the proposed system. This procedure leads to the dilution of sodium chloride content in seawater from the nominal value, which is approximately 0.55 mol l^{-1} [29] to 0.011 mol l^{-1} . In order to avoid difference on refractive index (Schelieren effect), which can appear when a spectrophotometric detection was employed [30], the carrier stream has to be the same matrix as sample solutions. Therefore, 0.011 mol l^{-1} of sodium chloride was added to the carrier solution.

Sodium chloride content in seawater sample may be different from the nominal value of 0.55 mol l^{-1} , which depends on the source of sampling area. In order to inspect the possibility to apply the proposed stopped-FI system to the determination of bromide in various content of sodium chloride in seawater, standard bromide solutions of 0 – $2.4 \mu\text{g ml}^{-1}$ were prepared in 0.010 , 0.011 and 0.012 mol l^{-1} of NaCl, which correspond to 0.5 , 0.55 and 0.6 mol l^{-1} of NaCl content in seawater, respectively. The linear equation obtained from these three conditions were $\text{Abs} = 0.135C_{\text{Br}^-} + 0.302$, $\text{Abs} = 0.138C_{\text{Br}^-} + 0.300$ and $\text{Abs} = 0.135C_{\text{Br}^-} + 0.296$, respectively, where Abs corresponds to the absorbance difference between the baseline and the minimum value of the

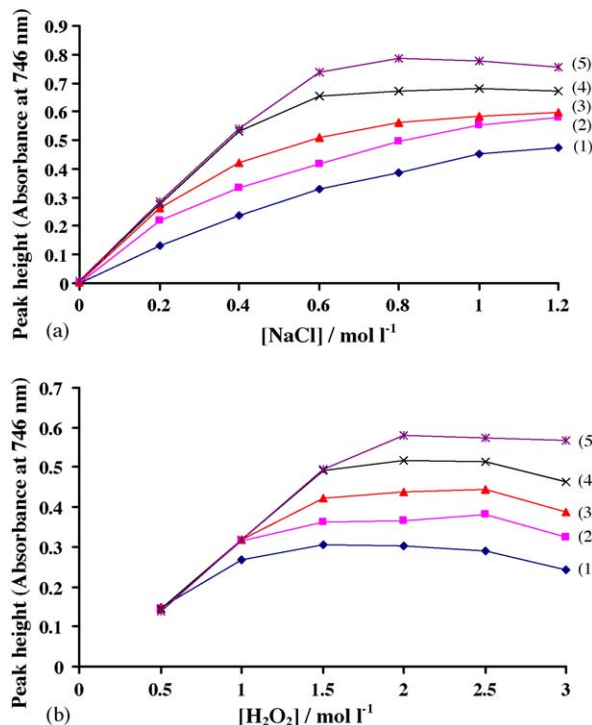

Fig. 4. Effect of concentrations of chemicals on analytical signal. (1–5) Standard bromide solutions of 0, 0.8, 1.6, 2.4 and $3.2 \mu\text{g ml}^{-1}$, respectively. (a) Effect of NaCl concentration (in mixed reagent) and (b) effect of H_2O_2 concentration.

hollows. The slope and the intercept of calibration graphs are almost identical. This indicates that the proposed stopped-FI system can be applied to the determination of bromide in differing content of sodium chloride in seawater. As a result, 0.011 mol l^{-1} of NaCl was used for the preparation of standard bromide solutions.

The optimization of NaCl concentration in mixed reagent and H_2O_2 concentration were done using a series of standard bromide solutions of 0 – $3.2 \mu\text{g ml}^{-1}$. As is described above, the catalytic effect of bromide on the oxidation of MB with H_2O_2 can be accelerated by the presence of chloride as an activator. The influence of NaCl concentrations in the range between 0 and 1.2 mol l^{-1} on sensitivity was investigated. The results shown in Fig. 4a demonstrate that in the absence of NaCl the sensitivity was very poor, while catalytic effect of bromide is appreciable when chloride is present at high concentrations. This behavior is probably due to the following chemistry: a large amount of chloride can partly be oxidized with an excess amount of hydrogen peroxide to chlorine, which can oxidize bromide to bromine. Finally, bromine can oxidize MB to the oxidation product. The response increased rapidly up to 0.6 mol l^{-1} ; therefore, this concentration was used for further studies due to good linearity of the calibration graph over the range of bromide concentration examined.

The effect of H_2O_2 concentration on the sensitivity was studied over the range of 0.5 – 3 mol l^{-1} . The results in

Fig. 4(b) show that the signal intensity increases with an increase in H_2O_2 concentration, and gradually decreases above 2 mol l^{-1} , which was chosen as optimal by considering on sensitivity and good linearity.

3.1.3. Optimization of FI variables

Variables affecting the performance of the proposed stopped-FI system for the determination of bromide were optimized. The variables examined for the optimization were the flow rate, mixing coil length and an injection volume. The optimization was carried out by repeating the sample injection ($n = 3$) of standard bromide solutions, 0 and $2.4 \mu\text{g ml}^{-1}$. The operational conditions of the FI system were obtained in a univariant way in order to achieve the best sensitivity with the appropriate analysis time during one injection run. When a stopped-flow technique was used, the timing of stopping the pump after the sample injections is very important. The time when the sample reaches the detection cell (traveling time) after the sample injection can be fixed by obtaining the traveling time for each FI parameter using a MB solution of $1 \times 10^{-3} \text{ mol l}^{-1}$. Water was pumped in all reagent channels and the sample loop was filled with MB solution. The FI parameters and their corresponding stopping times were verified for each variable. This parameter also affected on the analysis time. Therefore, the objective for the optimization of FI variables was to get a compromise between analytical signal and analysis time. "Analysis time" is defined as the time taken

from the injection of sample until the cycle of system is complete.

To simplify the optimization of the flow rate in the proposed stopped-FI system, the flow rate of all reagent and carrier stream were identical. The influence of total flow rate was investigated from 0.6 to 2.4 ml min^{-1} . The results are shown in Fig. 5a. The analytical signals obtained from the blank and the standard bromide of $2.4 \mu\text{g ml}^{-1}$ gradually increased with an increase in the flow rate. This is probably due to the better mixing achieved at the merging point in Fig. 1. Flow rate of 1.5 ml min^{-1} was selected for further studies as a compromise between sensitivity and sampling frequency.

The effect of mixing coil length was investigated in the range of 1–7 m. Results shown in Fig. 5(b) demonstrate that the increase in the coil length slightly decreases the signals for both the blank and the standard bromide. This is due to the increase of the dilution of the sample with increasing in the mixing coil length. Mixing coil of 5 m can offer a reasonable compromise between blank value and analysis time: 5 m was selected.

The influence of injection volume was examined by varying from 100 to $500 \mu\text{l}$. The results in Fig. 5(c) demonstrates that the analytical signals of standard bromide of 2.4 mol l^{-1} increase with increasing the sample volume, and the constant signals were obtained at the volumes greater than $200 \mu\text{l}$, whereas the blank signals and analysis time showed a little difference: a $200 \mu\text{l}$ was adopted.

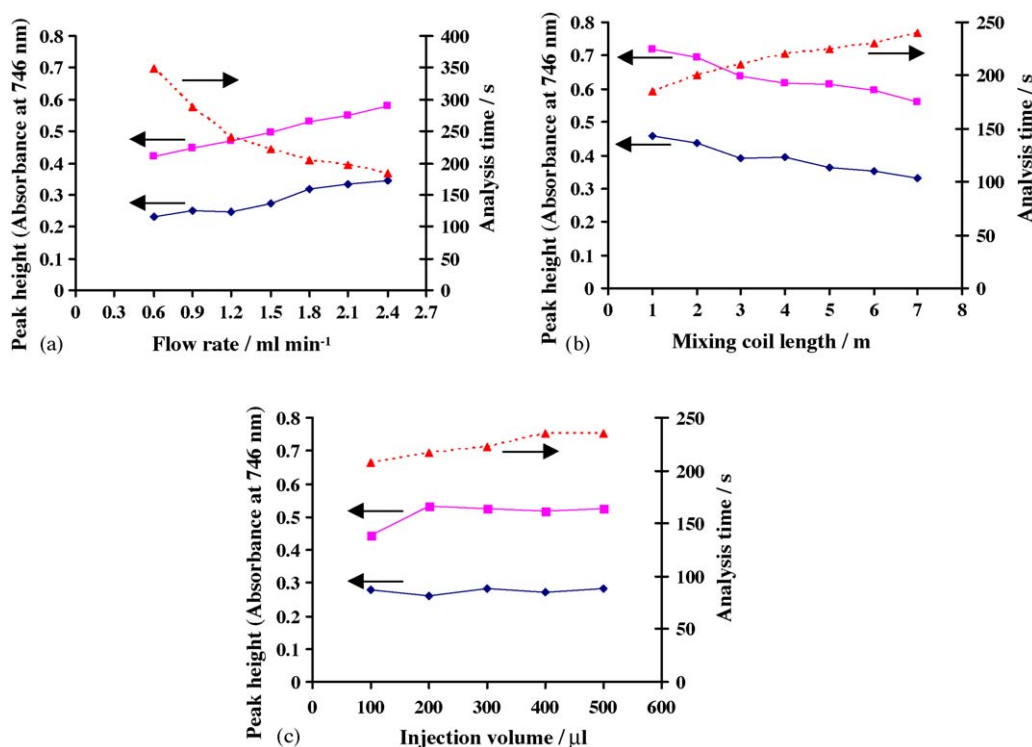

Fig. 5. Effect of FI variables on analytical signal of blank (◆) and $2.4 \mu\text{g ml}^{-1}$ of standard bromide (■), and analysis time (▲). (a) Effect of flow rate, (b) effect of mixing coil length and (c) effect of injection volume.

Table 2
Maximum tolerable concentrations of foreign ions

Ions	Tolerable concentrations ^a (mol l ⁻¹)
Co(II), Ni(II), Cd(II), As(V), Cr(III), Na ⁺ , K ⁺ , SO ₄ ⁻ , NO ₃ ⁻ , ClO ₃ ⁻ , ClO ₄ ⁻	2×10^{-2b}
Zn(II), Li ⁺	1.5×10^{-2}
Al(III), Fe(III), F ⁻	1×10^{-2}
Cu(II)	5×10^{-3}
Mn(II)	2×10^{-3}
Pb(II)	1×10^{-3}
V(V)	4×10^{-4}
Fe(II), Mo(VI)	6×10^{-5}
I ⁻	1.5×10^{-5}
NO ₂ ⁻ , ClO ⁻	1×10^{-5}

^a A $\pm 3\%$ relative error of the peak height for $1.6 \mu\text{g ml}^{-1}$ (2×10^{-5} mol l⁻¹) bromide was considered to be tolerable.

^b Maximum tolerable concentrations of ions tested.

3.2. Analytical characteristics

Using the optimized manifold under the optimum experimental condition, the calibration graph for the determination of bromide was prepared over the range of 0 to $3.2 \mu\text{g ml}^{-1}$. The typical stopped-FI profiles are shown in Fig. 2. The calibration equation was $\text{Abs} = (1.35 \pm 0.02) \times 10^{-1} C_{\text{Br}^-} + (2.72 \pm 0.06) \times 10^{-1}$; $R^2 = 0.999$, where C_{Br^-} is the concentration of bromide in $\mu\text{g ml}^{-1}$. Each point in the calibration graph corresponds to the average of three replicates injection of the standard bromide solutions. The repeatability of the method was calculated as the relative standard deviation (R.S.D.) of five replicates injection of $2.4 \mu\text{g ml}^{-1}$ of the standard bromide solutions, and the result obtained was 0.74%. The detection limit was $0.1 \mu\text{g ml}^{-1}$, which corresponds to the concentration of analyte giving signal equivalent to three times of the standard deviation of the blank signal (3σ of blank). The sample throughput was 12 h^{-1} .

3.3. Interference study

The effect of various potential interferences in seawater on the determination of bromide were investigated by analyzing synthetic sample solutions containing 2×10^{-5} mol l⁻¹ ($1.6 \mu\text{g ml}^{-1}$) of bromide together with various amounts of interfering ions. A given substance was considered to be toler-

Table 3
Recovery study of bromide added to seawater samples

Samples ^a	Bromide content ^b (50-fold diluted sample) ($\mu\text{g ml}^{-1}$)	Bromide added ($\mu\text{g ml}^{-1}$)	Found ^b ($\mu\text{g ml}^{-1}$)	% Recovery
1	1.23 ± 0.06	1.60	2.84 ± 0.08	101
2	1.22 ± 0.02	1.60	2.88 ± 0.03	104
3	1.13 ± 0.03	1.60	2.75 ± 0.06	101
4	1.25 ± 0.04	1.60	2.93 ± 0.06	105
5	1.24 ± 0.03	1.60	2.78 ± 0.10	96.2
6	1.36 ± 0.03	1.60	2.94 ± 0.04	98.5
7	1.38 ± 0.01	1.60	3.00 ± 0.05	102
8	1.39 ± 0.01	1.60	2.96 ± 0.02	98.2

^a Samples: seawater samples sampled at Seaside of Okayama Prefecture (1–5) and Seaside of Okinawa Prefecture (6–8).

^b Means (m) of three determinations; $m \pm \sigma$.

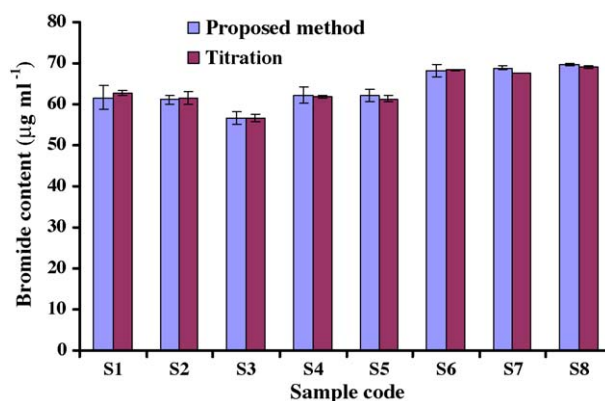

Fig. 6. Comparison of the bromide contents determined by the proposed method ($n=3$) and titration method ($n=3$).

able with the determination, if the deviation in the peak height of bromide was less than 3% compared with the standard bromide solution. The maximum tolerable concentrations of the interfering ions in the determination of 2×10^{-5} mol l⁻¹ of bromide are summarized in Table 2. It can be seen from the table that most of cations and anions normally present in seawater samples do not interfere with the determination of bromide in the proposed procedure, even at concentration of 2×10^{-2} mol l⁻¹. Ions, such as Fe(II), Mo(VI), I⁻, NO₂⁻ and ClO⁻, can interfere seriously with the determination of bromide. However, the dilution of seawater samples to 50-folds prior to the measurement of bromide can eliminate the interference from the above mentioned ions. The results demonstrate that the proposed method has the good selectivity for bromide determination.

3.4. Application to seawater samples and validation

In order to test the reliability of the proposed method, the method was applied to the determination of bromide in seawater samples. The recovery of bromide in the samples was checked by the addition of $1.6 \mu\text{g ml}^{-1}$ standard bromide to 50-fold diluted samples. The results are shown in Table 3. The recoveries were ranging from 96.2 to 105% ($n=8$), while indicates that no interfering substances encountered with the determination of bromide.

The proposed method was also validated by the titration method [28]. Bromide contents in eight kinds of seawater samples were determined. The results were compared with those given by the titration method as shown in Fig. 6. The results obtained by both methods are in good agreement with each other. According to paired *t*-test [31], no significant difference was found between the results of both methods at 95% confident limit ($t_{\text{observed}} = 0.49$, $t_{\text{critical}} = 2.36$).

4. Conclusion

A stopped-FI system using kinetic-spectrophotometric method for the determination of bromide was accomplished. The proposed procedure is simple and provides good reproducibility and accuracy. With respect of the advantage of the stopped-FI technique, the sensitivity of kinetic-based reaction can be improved, together with low dispersion and less consumption of the reagent. The method was applied successfully to the analysis of different source of seawater samples without interference effect of chloride, as well as other ions.

Acknowledgement

This work was supported partially by the Grant-in-Aid for Scientific Research (B) (No. 16350044) from Japan Society for the Promotion of Science (JSPS).

References

- [1] K.K. Verma, S.K. Sanghi, A. Jain, D. Gupta, *J. Chromatogr. A* 457 (1988) 345.
- [2] A. Jain, A. Chaurasia, B. Sahasrabudhhey, K.K. Verma, *J. Chromatogr. A* 746 (1996) 31.
- [3] H. Akaiwa, H. Kawamoto, M. Osumi, *Talanta* 29 (1982) 689.
- [4] S. Seefeld, U. Baltensperger, *Anal. Chim. Acta* 283 (1993) 246.
- [5] W. Hu, S. Cao, M. Tominaga, A. Miyazaki, *Anal. Chim. Acta* 322 (1996) 43.
- [6] S. Mishra, S. Gosain, A. Jain, K.K. Verma, *Anal. Chim. Acta* 439 (2001) 115.
- [7] K. Fukushi, K. Watanabe, S. Takeda, S. Wakida, M. Yamane, K. Higashi, K. Hiiro, *J. Chromatogr. A* 802 (1998) 211.
- [8] K. Fukushi, K. Watanabe, S. Takeda, S. Wakida, M. Yamane, K. Higashi, K. Hiiro, *J. Chromatogr. A* 802 (1998) 211.
- [9] P. Rantakokko, T. Nissinen, T. Vartiainen, *J. Chromatogr. A* 839 (1999) 217.
- [10] N. Kocatürk, N. Öztekin, F.B. Erım, *Anal. Bioanal. Chem.* 377 (2003) 1207.
- [11] P.I. Anagnostopoulou, M.A. Koupparis, *Anal. Chem.* 58 (1986) 322.
- [12] N. Yonehara, A. Kawasaki, H. Sakamoto, M. Kamada, *Anal. Chim. Acta* 206 (1988) 273.
- [13] W.J.M. Emaus, H.J. Henning, *Anal. Chim. Acta* 272 (1993) 245.
- [14] D.R. Jones, *Talanta* 40 (1993) 43.
- [15] C. Guoshu, F. Yunbing, *Fenxi Huaxue* 24 (1996) 741.
- [16] T. Tomiyasa, Y. Taga, H. Sakamoto, N. Yonehara, *Anal. Chim. Acta* 319 (1996) 199.
- [17] N. Pourreza, S. Rastegarzadeh, *J. Anal. Chem.* 56 (2001) 724.
- [18] A.A. Easafi, B. Rezaei, S. Nouroozi, *Spectrochim. Acta A* 60 (2004) 2053.
- [19] K. Uraisin, T. Takayanagi, M. Oshima, D. Nacapricha, S. Motomizu, *Talanta*, doi:10.1016/j.talanta.2005.06.061.
- [20] J. Ruzicka, E.H. Hansen, *Flow Injection Analysis*, second ed., Wiley, New York, 1988.
- [21] N. Yonehara, S. Chaen, T. Tomiyasu, H. Sakamoto, *Anal. Sci.* 15 (1999) 277.
- [22] A.A. Easafi, B. Rezaei, S. Nouroozi, *Spectrochim. Acta Part A* 60 (2004) 2053.
- [23] W.J.M. Emaus, H.J. Henning, *Anal. Chim. Acta* 272 (1993) 245.
- [24] P.R. Freeman, B.T. Hart, I.D. McKelvie, *Anal. Chim. Acta* 282 (1993) 379.
- [25] T. Masadome, Y. Asano, T. Nakamura, *Talanta* 50 (1999) 595.
- [26] E.P. Borges, A.F. Lavorante, B. Freire dos Reis, *Anal. Chim. Acta* 528 (2005) 115.
- [27] K. Grudpan, P. Ampan, Y. Udnan, S. Jayasvati, S. Lapanantnoppakhun, J. Jakmunee, G.D. Christian, J. Ruzicka, *Talanta* 58 (2002) 1319.
- [28] W.J. Williams, *Hand Book of Anion Determination*, Butterworths, Massachusetts, 1979, p. 272.
- [29] K.K. Turekian, *Oceans*, Prentice-Hall, 1968.
- [30] Z. Fang, *Flow Injection and Preconcentration*, VCH, New York, 1993.
- [31] J.N. Miller, J.C. Miller, *Statistics Chemometrics for Analytical Chemistry*, fourth ed., Pearson Education, Essex, 1993, pp. 48–50.